

Manufacturing of Small Electric Vehicle driven only by Electric Double Layer Capacitors for Easy Experiment of Vehicle Motion Control

Kiyotaka Kawashima, Toshiyuki Uchida, Yoichi Hori

Abstract

This paper presents the manufacturing of a novel small electric vehicle driven only by “Electrical double layer capacitors (EDLC)” as the energy source. This vehicle provides easy experiment of electric vehicle motion control, since it has extremely simple structure and helps us to perform some experiments easily taking advantage of the peculiar characteristic of large current charging. It shortens the charging time, which makes any experiments convenient and comfortable. In this paper, the basic characteristic of capacitor and basic driving experiment are shown and our future plans on vehicle motion control will be discussed.

Keywords: super capacitor, energy density, EV (electric vehicle), traction control, inverter

1 Introduction

In autumn 2003, "Japan Electron Optics Laboratory" announced that they developed a super capacitor whose energy and power density were raised as much as 10 times and equivalent to NiMH battery. It is said that the energy storage devices opened the gate into the completely new age. Generally speaking, super capacitor has the following characteristics.

- It can be charged and discharged without heat generation because it is not based on chemical reaction.
- Capacitor's voltage level tells us the remaining of energy level very precisely.
- Capacitor is very tough to endure the repetitions of charging and discharging.
- Capacitor is environmental friendly for not using heavy metals.
- The response of current absorption is very quick.

Generally, capacitors have been used as backup batteries of mobile PC's, printers, UPS's, etc. In the field of automobile, fuel-cell (hybrid) vehicles use capacitors not only for absorbing the regenerated energy but also for compensating the low efficiency of fuel-cell battery especially when the vehicle starts. Long life duration of super capacitor is also useful for starter battery on delivery track. This paper presents a novel small electric vehicle which has only EDLC as the energy source.

The aim of making this vehicle is to take the advantage of the peculiar characteristic of large current charging in EDLC. The basic characteristic of capacitor is shown and our future plan on vehicle motion control using this characteristic will be discussed.

2 Electrical double layer capacitor (EDLC)

2.1 Principal of electrical double layer (EDL)

The phenomenon of EDL was discovered by Helmholtz in 1879. The basic structure of Stern's EDL model is shown in Fig 1 [1].

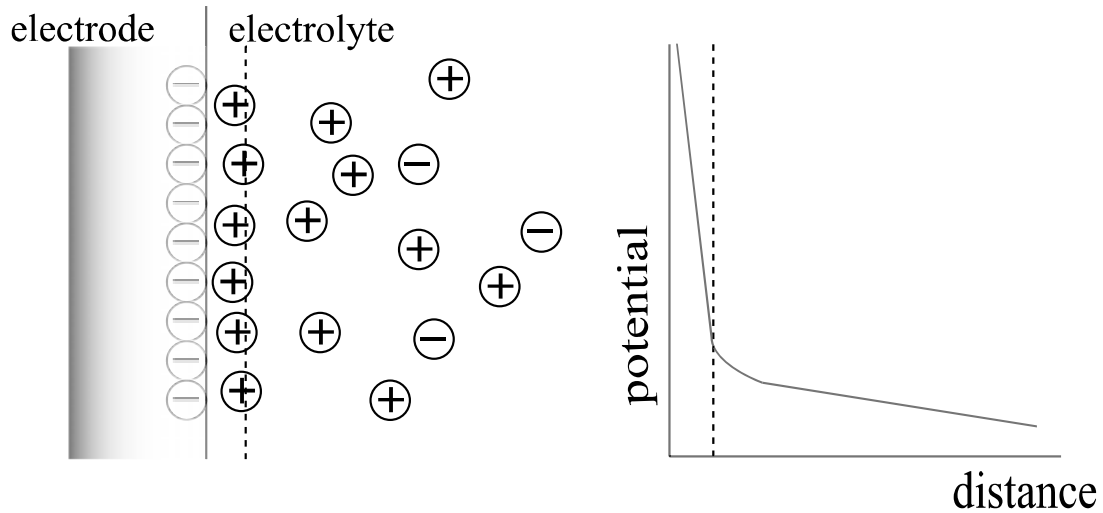

Fig 1: Stern's model of the Electrical Double Layer

EDL is composed of the thin monomolecular layer and the diffusion zone outside. These two layers are called EDL collectively.

EDLC consists of plural capacitor cells, and the maximum voltage is determined by electrical dissociation voltage endurance of the electrolyte. The electrolyte used in our manufacturing is the special ionized liquid with high ionized conduction.

An EDLC module has many capacitor cells. Therefore, repetition of charging/discharging and the variation among cell voltages cause serious degradation of capacitor. To overcome this problem, EDLC has a small electronic circuit which equalizes the voltage among cells.

2.2 Characteristics of the capacitor

Fig 2 depicts our EDLC module given by **Nisshinbo** and **Japan Radio Company**. The module has the special voltage equalization circuit. It prevents voltage variation among capacitor cells charging and stretches the capacitor's life expectancy. Table 1 indicates the specification of EDLC module.

Table 1: Specification of .EDLC module

Voltage	100V
Capacitance	26.7F
Internal Resistance	80mΩ
Mass	12.4kg
Volume	287×260×161mm
Self discharging current	16.8mA



Fig 2: EDLC module

Fig 3 shows the result of measurement of charging/discharging characteristic of the EDLC module.

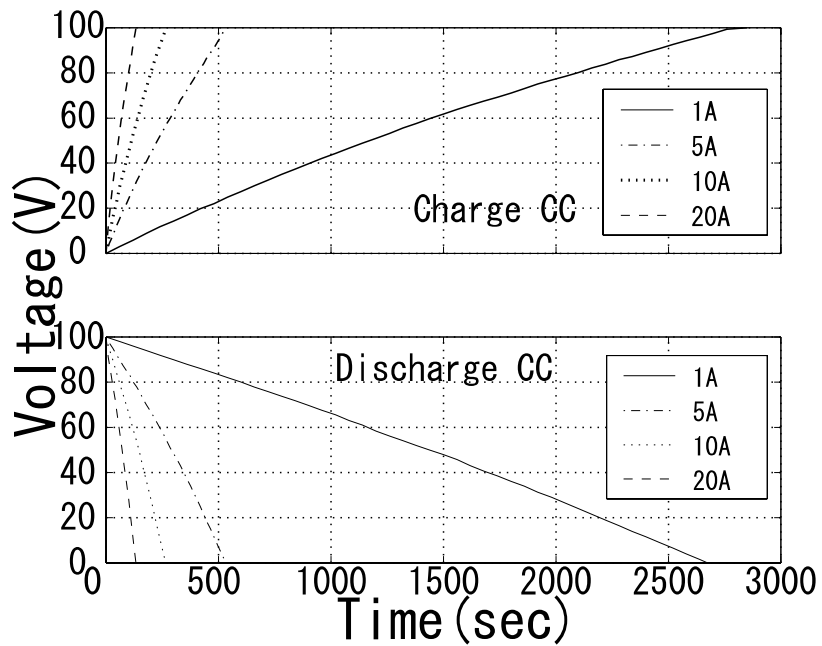

Fig 3: Charging/discharging characteristics

The lines in Fig 3 satisfy the equation of

$$V = \frac{I}{C}t \quad (1)$$

very well, and this results show that the capacitor is following the ideal property of capacitance.

- Capacitance

From the gradient of the line in Fig 3, capacitance C in eq(1) is obtained. Calculation results are shown in Table 2. The approximated capacitance of the EDLC is 26.7F.

Table 2: Calculation result of capacitance

Current (A)	1	5	10	20
Capacitance (F)	26.8	26.8	26.6	26.7

- Internal resistance

The internal resistance is measured by means of voltage drop on discharging. The experimental results are shown in Fig 4 (a) (b). According to the results, the internal resistance is calculated as about 80m Ω . This value confirms that the internal resistance of the EDLC is very small.

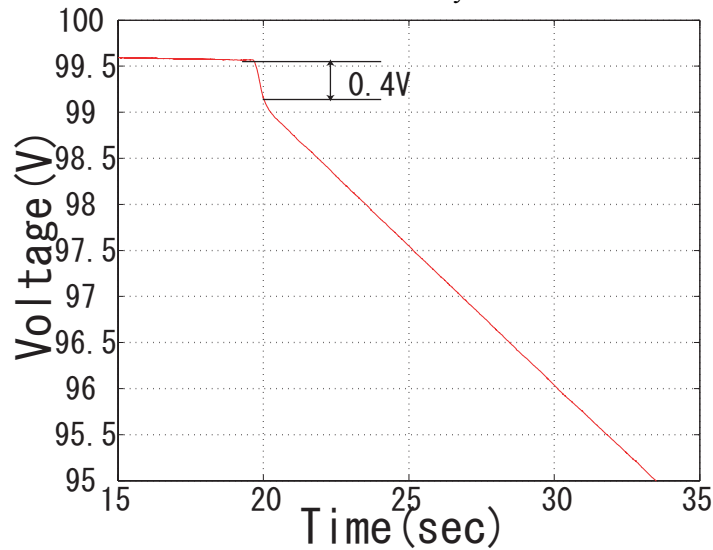

(a) 5A discharging

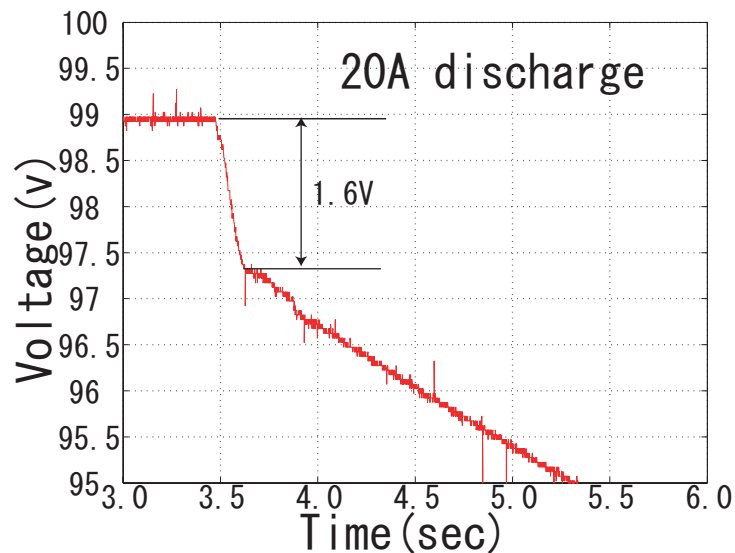

(b) 20A discharging

Fig 4: Voltage drops on discharging

2.2 Comparison with other secondary batteries

Table 3 shows the comparison of EDLC parameters with other secondary batteries.

Table 3: Comparison with other secondary batteries

	Energy density		Power density	Cycle
	Wh/kg	Wh/l	W/kg	
Lead	36	95	200	< 500
NiMH	65	155	200	< 500
Li-ion	110	160	200	500
EDLC	2.8	4.3	1330	Semi permanent

Although the EDLC's energy density is very small, the power density is 6.5 times as large as other devices and cycle life is semi permanent. These characteristics enable fast charging and make an electric vehicle suitable for experiments of motion control, where lots of experiments are needed in the same condition in short experimental time.

3 Vehicle system

3.1 Specifications

COMS, used in our research, is a one-seater vehicle made by Toyota Auto Body Co., Ltd. Fig 5 shows its outlook. These small electric vehicles are often used in delivery service because it saves space and is easy to drive.



Fig 5: Small vehicle COMS

Drive train consists of batteries, inverters and brushless DC motors. In detail, see Table 4.

As the motors are very small, two motors are installed in rear wheels. This makes it possible to drive each motor independently, which will realize novel motion control of vehicle dynamics. For example, control with independent wheel torque control [2], yaw-moment stabilizing control using yaw-moment observer [3] can be investigated. Self-aligning torque estimation [4] and cornering stiffness estimation [5] are also important research subjects.

We explain some of these control techniques in more details in a following section.

Table 4: Drive train

Motor	
Category	PSM
Phase/Pole	3/12
Rating power/Max	0.29kW/2kW
Max torque	100Nm
Max speed	50km/h
Inverter	
Hardware	Transistor inverter
Control method	PWM vector control

3.2 System

Vehicle system is shown in Fig 6. LINUX PC calculates the command torque to the inverter from the velocity from each tire, rudder angle of steering wheel, acceleration and yaw rate information. The sampling time is 1 msec.

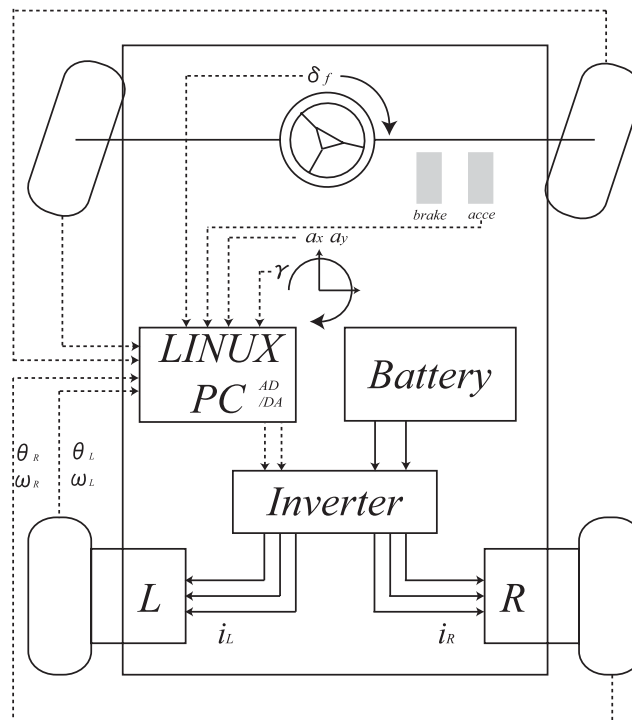

Fig 6: Vehicle system

4 Installation of the Capacitor and Driving Experimental Result

Fig 7 shows the installation frame for three EDLC modules in the rear space.

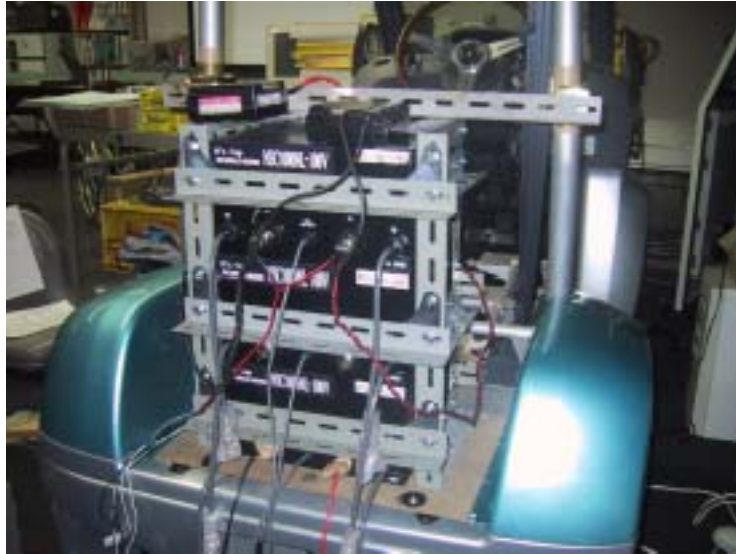
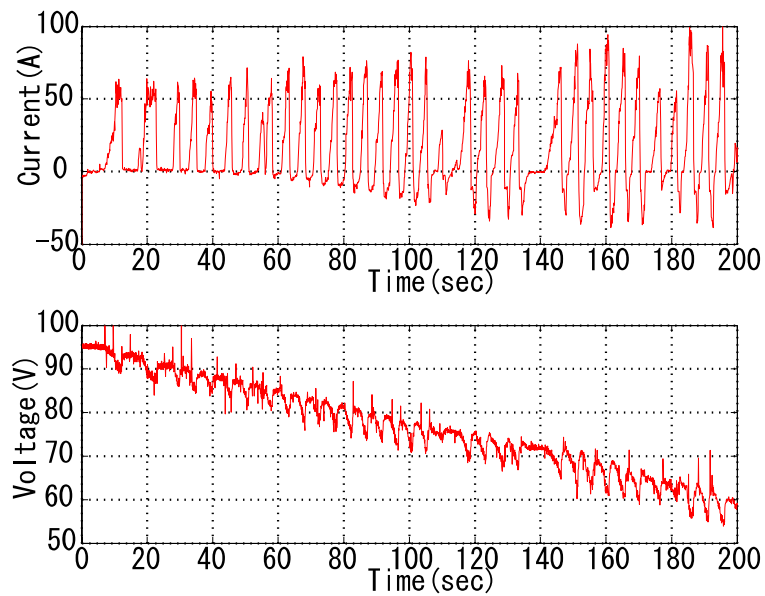

Fig 7: Installation of EDLC module

Basic driving experiment was performed, and the results are in Fig 8. Driving course is a track and it took about 20 seconds per lap. As the vehicle is accelerated, the current increases.



(a) Transition of voltage

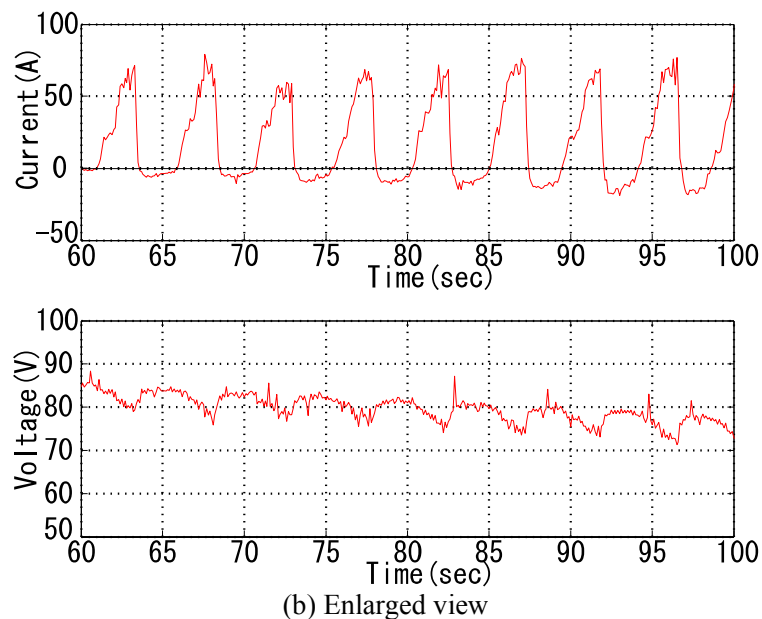

Fig 8: Transition of capacitor voltage and current

This experiment explains three notable typical points of capacitor.

At first, the voltage decreases with driving, so we can know the remaining energy level properly.

Secondly, the voltage level drastically rises about 3 or 4V (see Fig 8 (b)) because the internal resistance of EDLC apparently drops the voltage level. If the current becomes zero, it looks that the voltage level suddenly rises. Generally the resistance of EDLC is low(80m Ω :direct current), so the fluctuation of voltage does not have much effect on the system.

Lastly, the regenerating current is zero until the voltage reaches about 85V because the motor regenerative voltage is lower than the EDLC's one. Therefore the regenerating brake has an effect in the middle and low voltage region.

5 Motion Control Using Electric Vehicle

5.1 Advantages of Motor Comparing to the Internal Combustion-engine

As we have pointed out, electric vehicle has the following four remarkable advantages:

- Motor's torque generation is 10-100 times faster than engine. This advantage enables us to realize high performance adhesion control, e.g., skid prevention and slip control.
- Motor's torque can be known easily by observing the motor current. This property can be used for road condition estimation.
- As a motor is compact and not so expensive if it is divided into four, it can be equipped for each wheel. This realizes high performance vehicle motion control.
- There is no difference between acceleration and deceleration control. Just by changing the direction of motor current, the vehicle can be decelerated.[6]

In the next section, we introduce and categorize the possible EV motion control techniques which can be realized taking these advantages.

5.2 Advantages of Motion Control on Electric Vehicle

- **Adhesion control of tire and road surface**

This control method takes the advantage of an electric motor most effectively.

1. MFC (to be described later);
2. Slip ratio control;
3. Cooperation with higher level control like DYC (to be described later);
4. Wheel skid detection without vehicle speed knowledge.

- **High performance braking control**

Motor's controllability enables us a higher performance of braking control system.

1. Pure electric braking control in a whole speed range;
2. Hybrid ABS for HEV; combination of hydraulic brake and motor brake;
3. Direct control of driving force at each tire.

- **Two-dimensional attitude control**

The aim of this control is to find the optimal combination of controlling β and γ .

1. Decoupling control β and γ ;
2. Higher performance coordination of AFS and DYC;
3. Vehicle dynamics control based on β estimation;
4. Dynamic driving force distribution considering side slip force and cooperation with suspension system under changing load.

- **Road surface condition estimation**

Using the motor characteristic of easy torque observation, we can estimate various kinds of parameters.

1. Estimation of gradient of μ - λ curve;
2. Estimation of the maximum friction coefficient;
3. Estimation of the optimal slip ratio to be used for SRC;
4. Higher performance DYC based on the estimation of road surface condition.

In these control techniques, we discuss on MFC and DYC in the next section.

5.3 Anti Skid Control based on MFC (Model Following Control)

In this section, anti skid control using disturbance observer is proposed.

One-wheel model is described as the following equations.

$$M_w \dot{V}_w = F_m - F_{df} \quad (2)$$

$$M \dot{V} = F_{df} \quad (3)$$

Where M and M_w are the mass of the vehicle and wheel respectively, F_b is hydraulic braking force, F_{mr} is motor torque and F_{df} is driving force [6][7].

Fig 9 explains this idea easily. A motor directly connects to a tire and the ground surface transmits the driving force to vehicle body.

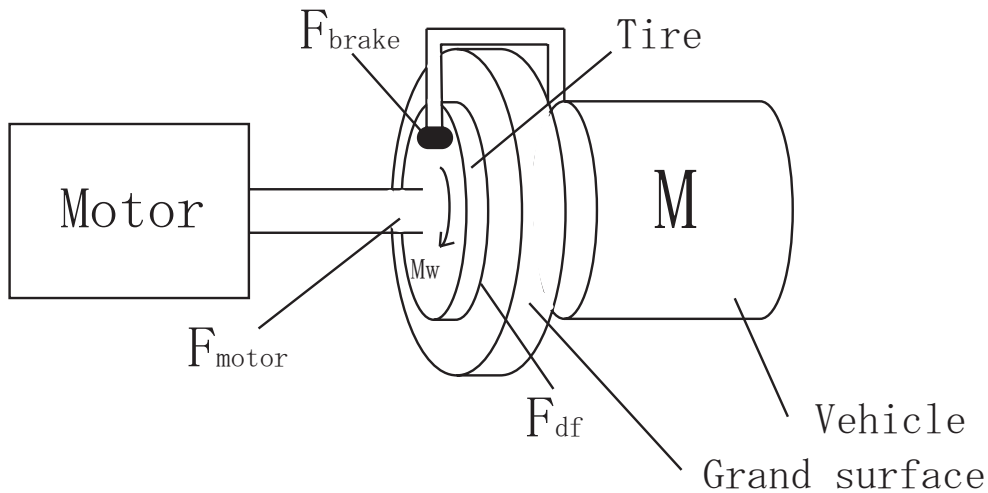

Fig 9: Wheel model

If the road-surface condition is changed and μ becomes low during braking, braking-force would be sharply reduced. The rapid decrease of braking force will cause skid and make the vehicle motion unstable. In order to prevent such tire skidding, the driver's torque command should be treated as the increase of disturbance force. Considering this point, we can design the feedback control to reduce the driver's torque. This control strategy, called model following control (MFC) [6], demonstrates that the motor control can change the mechanical characteristics. Fig 10 is the block diagram of the MFC.

Motor MFC can prevent the tire slip and skid quickly and more accurately than internal combustion one. Furthermore motor can be distributed in each wheel, so minor slip/skid control can be realized.

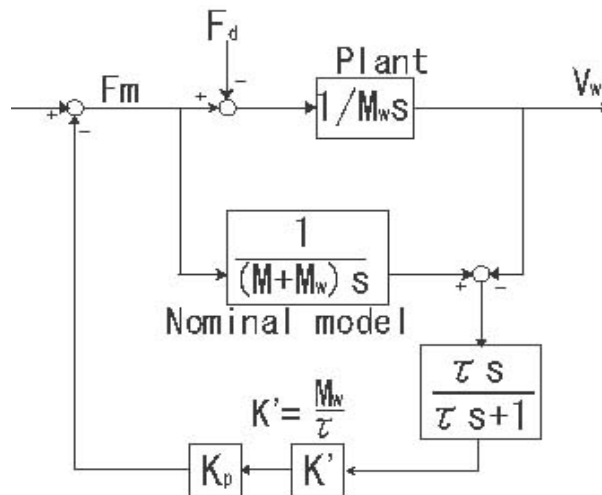

Fig 10: Block diagram of MFC

5.4 Two-dimensional Attitude Control (DYC : Direct Yaw-moment Control)

Distributed motors in each wheels means that each motors can drive independently. If left and right motors output different torques, yaw moment is generated on the center of the axle. Appropriate yaw moment stabilizes the vehicle behavior in dangerous turning.

Yaw rate control of DYC method is shown in Fig 11. Yaw rate command is made from steering angle with first order delay. PI gains are determined by the Coefficient Diagram Method (CDM). Abe's basic vehicle equation [8] is used for the vehicle model in Fig 11.

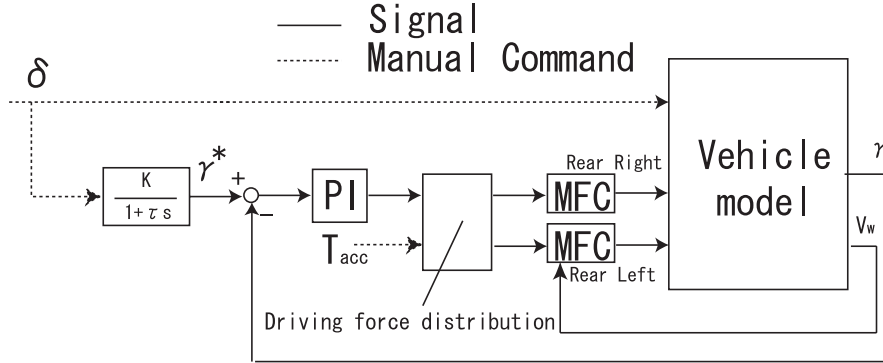

Fig 11: Control system

Detail of driving force distribution block is shown below.

Using the control input M and the acceleration input T_{acc}^* , the right and left torque T_r^* , T_l^* input is calculated according to the following equation, where d denotes the length of the axle, r the radius of the wheel.

$$T_{acc}^* = T_r^* + T_l^* \quad (4)$$

$$M = \frac{d}{2}(T_r^* / r - T_l^* / r) \quad (5)$$

Conclusion

Experimental manufacturing and driving experiment of small electric vehicle were conducted with EDLC module as the energy source. It was verified that charging time of EDLC is much shorter than lead acid batteries. Coming of an ubiquitous society, the role of power sources would be more important part. Based on the fact, we note the EDLC whose energy density drastically increases and proposed the novel usage of taking the EDLC as the power source of electric vehicle. At the last section, we listed up various future techniques to be done using this vehicle. We are planning to perform some of them and report at the conference.

References

- [1] Michio Okamura, *Electrical double layered capacitor and storage system (in Japanese)*, pp.25-31, Nikkan-Kogyo-Shimbunsha
- [2] Motoki Shino, Masao Nagai, *Independent wheel torque control of small-scale electric vehicle for handling and stability improvement*, JSAE Review, Vol.24, pp.449-456, 2003
- [3] Hiroshi Fujimoto, Takeo Saito, Toshihiko Noguchi, *Yaw-moment stabilizing control of small electric vehicle*, AMC2004-Kawasaki, pp.35-40, 2004
- [4] Daisuke Sekiguchi, Toshiyuki Murakami, *Vehicle steering assist by estimated self aligning torque in skid condition*, AMC2004-Kawasaki, pp.269-273, 2004
- [5] Akio Tsumasaka, Hiroshi Fujimoto, Toshiyuki Noguchi, *Cornering stiffness estimation of electric vehicle based on yaw-moment observer (in Japanese)*, National Convention Record IEE of Japan –Industry Applications Society-, pp.II 551-552, 1987

[6] Yoichi Hori, *Future Vehicle driven by Electricity and Control-Research on Four Wheel Motored "UOT Electric March II"*, IEEE Transaction on Industrial Electronics, Vol.51, No.5, October 2004

[7] Shinichiro Sakai et al., *Novel skid detection method without vehicle chassis speed for electric vehicle*, JSAE Review (Elsevier Science), Vol.21, No.4, pp.504-, 2000

[8] Masato Abe, *Vehicle dynamics and control (in Japanese)*, Sankaido, 1992

Author



Kiyotaka Kawashima

Department of Electrical Engineering the University of Tokyo, 7-3-1 Hongo Bunkyo-ku Tokyo 113-8656, Japan

Tel: +03 5452 6289, Fax: +03 5452 6288 E-mail: kawashima@horilab.iis.u-tokyo.ac.jp

He received B.C. degree in Electrical Engineering from the University of Tokyo in 2004, and proceeded to master course in the University of Tokyo. He is now researching the motion control of electric vehicle and estimating the ELDC as the power source of electric vehicle.



Toshiyuki Uchida

Department of Electrical Engineering the University of Tokyo, 7-3-1 Hongo Bunkyo-ku Tokyo 113-8656, Japan E-mail: uchida@horilab.iis.u-tokyo.ac.jp

He is working as an engineering official in Department of Electrical Engineering the University of Tokyo



Yoichi Hori

The Institute of Industrial Science the University of Tokyo, 4-6-1 Komaba Meguro-ku Tokyo 153-8505, Japan

Tel: +03 5452 6289, Fax: +03 5452 6288 E-mail: hori@iis.u-tokyo.ac.jp

He received Ph.D degrees in Electrical Engineering from the University of Tokyo in 1983 and joined the Department of Electrical Engineering as a Research Associate. He later became a Professor in 2000. In 2002, he moved to the Institute of Industrial Science as a Professor of Information & Electronics Division. His research fields are control theory and its industrial application to motion control, mechatronics, robotics, electric vehicle, etc. He worked as Treasurer of IEEE Japan Council and Tokyo Section during 2001-2002. He is now the Vice President of IEE-Japan IAS. He is the program chairperson of the coming EVS-22 to be held in Yokohama, October 2006. IEEE Fellow.